

INSTRUCTIONS FOR USE

44XXXXX Series Roto-Loc™ Self Retracting Lanyards

Complies with the current ANSI Z359.14-2014 and all applicable OSHA regulations and requirements.

**Reliance Industries
P.O. Box 2046
Deer Park, TX 77536**

**Phone : 281-930-8000
Toll Free : 888-362-2826
Fax : 281-930-8666**

Contents

DESCRIPTION	3 - 4
PRODUCT SPECIFICATIONS	5
APPLICATION	5
A. PURPOSE	5
1) PERSONAL FALL ARREST	5
B. USE LIMITATIONS	6
1) CAPACITY	6
2) FREE FALL	6
3) FALL CLEARANCE	7 - 8
4) SWING PENDULUM FALLS	8 - 9
5) CHEMICAL HAZARDS	9
6) HEAT	9
7) CORROSION	9
8) ELECTRICAL HAZARDS	9
9) MOVING MACHINERY	10
10) SHARP EDGES AND ABRASIVE SURFACES	10
11) WEAR AND DETERIORATION	10
12) IMPACT FORCES	10
SYSTEMS REQUIREMENTS	10
A. COMPATIBILITY OF SYSTEM PARTS	10
1) COMPATIBILITY OF COMPONENTS AND SUBSYSTEMS	10
2) COMPATIBILITY OF CONNECTORS	11
3) ANCHORAGES AND ANCHORAGE CONNECTORS	11
INSTALLATION PROCEDURE	12
A. CONNECTING THE SRL TO AN ANCHOR POINT	12
B. CONNECTING THE SRL TO A HARNESS	12 - 13
C. PREPARATION FOR USE	14
D. INSPECT PRIOR TO USE	14
E. PLAN SCOPE OF WORK TO BE PERFORMED ANALYSIS)	14 - 16
CARE OF THE ROTO-LOC	16
INSPECTIONS	16
A. INSPECTION FREQUENCY	16
B. INSPECTION PROCEDURE	17 - 18
TRAINING	18
RESCUE PLANNING	19
SERVICING	19
GUARDING AGAINST APPLICATION FAILURE	19
WARNINGS AND LIMITATIONS	20
LABELING	21
INSPECTION RECORD	22
PART NUMBER LIST	23
WARRANTY STATEMENT	23

Instructions for Use

User Instructions Reliance Self Retracting Lanyards

User Instruction Manual - Self Retracting Lanyards

This manual is intended to meet the Manufacturer's Instructions as required by the current ANSI Z359.14-2014, and should be used as part of an employee training program as required by OSHA.

WARNING

This product is one part of a personal fall arrest, restraint, work positioning, personnel riding, climbing, or rescue system. Without the other necessary components in such sub-systems the Self Retracting Lanyard itself serves no useful purpose. The user must follow the manufacturer's instructions for each component of the system. These instructions must be provided to the user before using this product and retained for ready reference by the user. The user must read, understand (or have explained), and heed all instructions, labels, markings and warnings supplied with this product and with those products intended for use in association with it before using this equipment. Manufacturer's instructions must be followed for proper use and maintenance of this equipment. National standards and state, provincial and federal laws require the user to be trained before using this product. This manual can be used as part of a such a user safety-training program that is appropriate for the user's occupation.

IMPORTANT: Alterations or misuse of this product or failure to follow instructions may result in serious injury or death. If you have questions on the use, care, or suitability of this equipment for your application, contact RELIANCE Fall Protection for information.

DESCRIPTION

The Roto-Loc™ Leading Edge Self Retracting Lanyard (SRL-LE) is designed to be a component in a personal fall arrest systems (PFAS). It may be used in most situations where a combination of worker mobility and fall protection is required (i.e. inspection work, general construction, maintenance work, steel stick work, etc.). The Roto-Loc™ SRL-LE is designed for use by a single person weighing up to 310 lbs [141kg] (body weight plus tools) Roto-Loc™ Leading Edge Self Retracting Lanyard features a cam-action Stop-Cap Pawl system ensuring positive lock-up even in the most demanding environments. The SRL-LE's are mounted at the dorsal D-ring location of the users full body harness. Models are available in both single and twin SRL-LE configurations which incorporate both Pelican™ and Rebar snap hooks. The unique hook body design's prevent the accidental "false engagement" to the anchorage structure or D-ring, while the case swivel provides an easy to see load indicator showing whether the Roto-Loc™ Leading Edge Self Retracting Lanyard has been exposed to a fall arrest load and needs to be serviced.

Identifying Components of Roto-Loc™ Leading Edge Self Retracting Lanyards

Figure 1 - Single

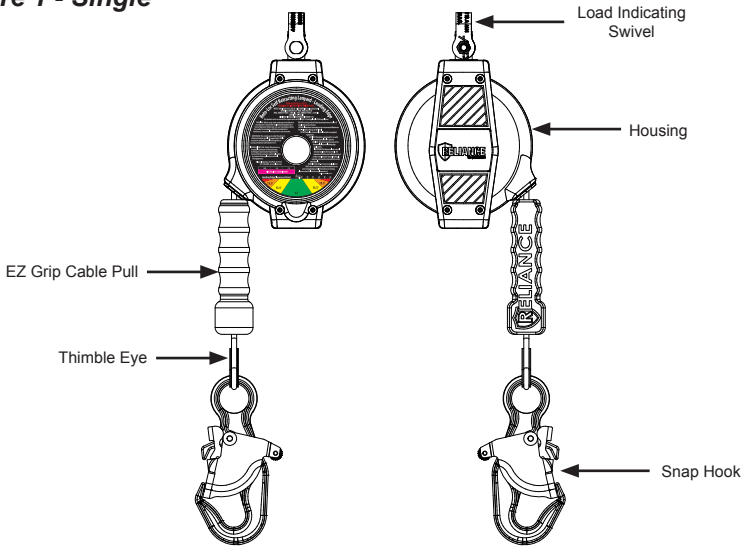

4485006-1, 4486006-1, 4487006-1, 4480006-1

Figure 2 - Twin

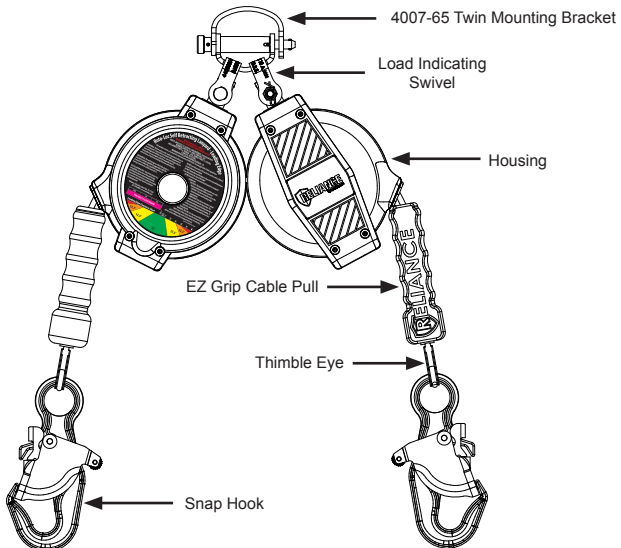

4495006-1, 4496006-1, 4497006-1, 4490006-1

Instructions for Use

PRODUCT SPECIFICATIONS

Part #	Working Length	Line Type	Weight	SRL Type	Hook Type	Housing Type	Housing Dimensions
4485006-1	6' (1.8m)	3/16" (4.5mm) Galvanized	4.9	Single	3006WR Pelican ZN Plate	Sanoprene over ABS	8"Lx5"Wx3.5"H (20.3cmX12.7cmX88.9cm)
4486006-1	6' (1.8m)	3/16" (4.5mm) Galvanized	5.6	Single	3011WR Rebar ZN Plate	Sanoprene over ABS	8"Lx5"Wx3.5"H (20.3cmX12.7cmX88.9cm)
4487006-1	6' (1.8m)	3/16" (4.5mm) Galvanized	5.1	Single	Steelhead HD ZN Plate	Sanoprene over ABS	8"Lx5"Wx3.5"H (20.3cmX12.7cmX88.9cm)
4480006-1	6' (1.8m)	3/16" (4.5mm) Galvanized	5.5	Single	Pelican Swivel ZN Plate	Sanoprene over ABS	8"Lx5"Wx3.5"H (20.3cmX12.7cmX88.9cm)
4495006-1	6' (1.8m)	3/16" (4.5mm) Galvanized	10.1	Twin	3006WR Pelican ZN Plate	Sanoprene over ABS	8"Lx5"Wx3.5"H (20.3cmX12.7cmX88.9cm)
4495006-Z	6' (1.8m)	3/16" (4.5mm) Galvanized	10.1	Twin	3006WR Pelican ZN Plate	Sanoprene over ABS	8"Lx5"Wx3.5"H (20.3cmX12.7cmX88.9cm)
4496006-1	6' (1.8m)	3/16" (4.5mm) Galvanized	11.5	Twin	3011WR Rebar ZN Plate	Sanoprene over ABS	8"Lx5"Wx3.5"H (20.3cmX12.7cmX88.9cm)
4496006-Z	6' (1.8m)	3/16" (4.5mm) Galvanized	11.5	Twin	3011WR Rebar ZN Plate	Sanoprene over ABS	8"Lx5"Wx3.5"H (20.3cmX12.7cmX88.9cm)
4497006-1	6' (1.8m)	3/16" (4.5mm) Galvanized	10.5	Twin	Steelhead HD ZN Plate	Sanoprene over ABS	8"Lx5"Wx3.5"H (20.3cmX12.7cmX88.9cm)
4490006-1	6' (1.8m)	3/16" (4.5mm) Galvanized	11.3	Twin	Pelican Swivel ZN Plate	Sanoprene over ABS	8"Lx5"Wx3.5"H (20.3cmX12.7cmX88.9cm)

The following specifications apply to all Roto-Loc™ Leading Edge Self Retracting Lanyards and meet the Class A requirements of ANSI Z359.14-2014:

- **MAXIMUM ARREST FORCE (MAF):** ≤ 1,800 lbs (8kN)
- **AVERAGE ARREST FORCE (AAF):** ≤ 1350lbs(6kN)
- **OVERHEAD ARREST DISTANCE (AD):** ≤ 24" (6m)
- **LEADING EDGE ARREST DISTANCE:** See Charts to follow
- **310 LB MAX. CAPACITY :** 1 worker, max. combined tool & body weight ≤ 310 lbs (140.6kg).

LEADING EDGE SELF RETRACTING LANYARD APPLICATION

A. PURPOSE:

RELIANCE Leading Edge Self Retracting Lanyards (SRL-LE's) are used as one component in a personal fall arrest system (PFAS). The SRL-LE's described in this manual meet, ANSI Z359.14 and OSHA requirements. These instructions, and markings borne by the SRL-LE's, fulfill the instruction and marking requirements of those standards and regulations. This equipment is specifically designed to dissipate fall energy and limit the fall arrest forces that are transferred to the body. **The SRL-LE can only be mounted to the users dorsal D-Ring for Leading Edge applications.**

1) PERSONAL FALL ARREST:

The Self Retracting Lanyard is used as a component of a personal fall arrest system. Personal fall arrest systems typically include a full body harness, a

connecting subsystem (energy absorbing device such as a shock absorbing lanyard or Self Retracting Lanyard) and an anchorage connector. Average arresting force must not exceed 1350 lbs (1kN) for ANSI Z359.14-2014 and 1,800 lbs MAF (8kN) for OSHA.

B. USE LIMITATIONS:

Consider the following application limitations before using this equipment:

1) CAPACITY:

These SRL's are designed for use by persons with a combined weight (clothing, tools, etc.) of no more than 310 lb Max. Capacity: 1 worker.

WARNING

Persons with muscular, skeletal, or other physical disorders should consult a physician before using. Pregnant women and minors must never use this equipment. Increasing age and diminished physical fitness may reduce a person's ability to withstand shock loads during fall arrest or prolonged suspension. Consult a physician if there is any question about a users physical ability to safely use this product to arrest a fall or remain suspended.

2) FREE FALL:

When anchored overhead, SRL-LE's will limit the arrest distance to 2 ft. (61cm) or less. To avoid increased fall distances, anchor the SRL-LE directly above the work level. Avoid working where your lanyard may cross or tangle with that of another worker. Avoid working where an object may fall and strike the lanyard; resulting in loss of balance or damage to the lanyard. Do not allow the lanyard to pass under arms or between legs. Never clamp, knot, or prevent the lanyard from retracting or being taut. Avoid slack line. Do not lengthen SRL-LE by connecting a lanyard or similar component.

WARNING

Do not allow the Lanyard to pass under arms or between legs. Never clamp, knot, or prevent the Lanyard from retracting or being taut. Avoid slack line. Do not lengthen the SRL by connecting a lanyard or other components without consulting Reliance.

ALLOWABLE ANGLE OF REDIRECTION

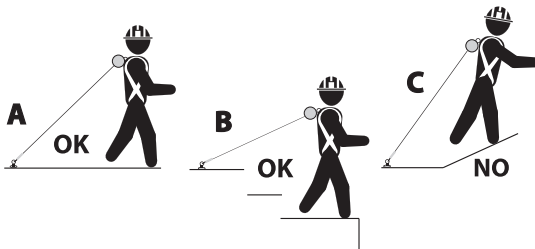

WARNING

Use of this device while attached to a "foot-level" anchorage or while exposed to an unprotected structural edge should be a LAST RESORT. Every effort should be made to attach to a properly rated overhead anchorage in an effort to reduce the overall fall distance. DO NOT allow the retractable line to come into contact with a sharp, jagged, serrated or abrasive edge. A "foot-level" or "leading-edge" fall is likely to result in the injury of the user – the first hazard in the fall path is and always will be the structural edge, itself! Elevate your anchorage to the extent possible for the best outcome.

Instructions for Use

WARNING

The allowable angle of redirection of the Lanyard at the edge over which a fall might occur, measured by the two sides formed by the redirected Lanyard must be at least 90 degrees. In other words, working above the level at which the SRL-LE is anchored and being exposed to an edge hazard is dangerous because this will cause the Lanyard to 'redirect' at a sharper angle if a fall occurs and may cut or damage the Lanyard. In addition, do not work on the far side of an opening, opposite the SRL-LE anchorage point. Failure to heed these warnings may result in serious injury or death.

3) FALL CLEARANCE:

Figures 2 and 3A through 3B illustrate Fall Clearance requirements. Ensure adequate clearance exists in the fall path to prevent striking an object during a fall. If a user is working at a position that is not directly below the SRL-LE anchorage point, the clearance required and vertical fall distance increase. Figure 3A and 3B provide the clearance requirements when using the SRL-LE for leading edge applications.

Determine Fall Clearance Required: To determine the fall clearance required, measure the distance from the user's harness dorsal connection to the anchorage for the SRL-LE. Both horizontal and vertical distances are required. Use Figures 2 and 3A through 3B, to determine the required clearance. The lines in the figures represent 1 foot (0.3 m) increments from the user's harness dorsal connection to the anchorage. For example, 12 ft of clearance is required when the SRL-LE unit is anchored 2 ft back and 0 ft to the side of the user's harness dorsal connection for users up to 310 lbs (141 kg).

WARNING

The clearances provided here assume the fall occurs from a standing position. If the worker is kneeling or crouching an additional 3 ft (0.9m) clearance is needed. Failure to heed this warning may result in serious injury or death.

FIGURE 2		Anchorage Offset From Back D-Ring												
		6'	5'	4'	3'	2'	1'	0	1'	2'	3'	4'	5'	6'
Anchorage Level Above Back D-Ring	6'							3.0						
	5'				4.0	3.0	3.0	3.0	3.0	3.0	4.0			
	4'			4.5	4.0	3.5	3.0	3.0	3.0	3.5	4.0	4.5		
	3'	5.5	4.5	4.0	3.5	3.5	3.5	3.5	3.5	3.5	4.0	4.5	5.5	
	2'	5.5	4.5	4.5	4.0	3.5	3.5	3.5	3.5	3.5	4.5	4.5	5.5	
	1'	6.0	5.0	4.5	4.0	4.0	3.5	4.0	4.0	4.5	5.0	6.0		
Back D-Ring	0	6.0	5.0	4.5	4.0	4.0	4.0	4.0	4.5	5.0	6.0			
Anchorage Level Below Back D-Ring	1'	7.0	6.5	5.5	5.5	5.0	6.0	5.5	5.5	6.5	7.0			
	2'	8.5	7.5	6.5	6.5	6.0	6.0	6.5	6.5	7.5	8.5			
	3'	9.5	8.5	8.0	7.5	7.5	7.5	7.5	7.5	8.0	8.5	9.5		
	4'		10.0	9.0	9.0	8.5	8.5	8.5	9.0	9.0	10.0			
	5'			10.0	10.0	10.0	10.0	10.0	10.0	10.0				
	6'						12.0							
Clearance (Feet) Between Working Surface and Nearest Obstruction Extension, Free Fall, 2 Foot Safety Factor												(Includes SRL)		

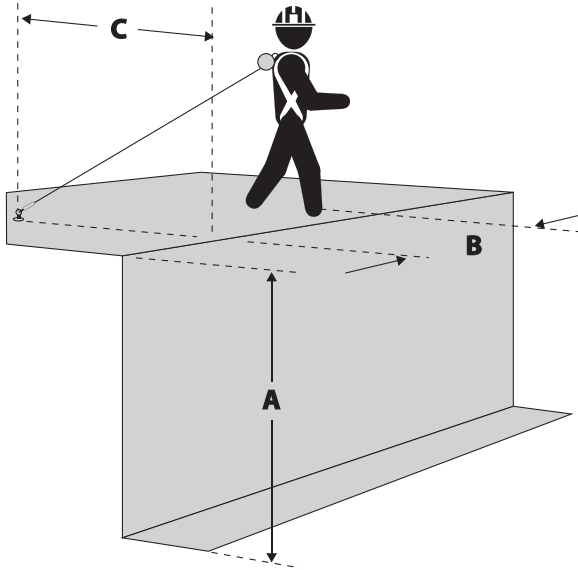

FIGURE 3A

FIGURE 3B		Clearance Required (A) When Falling Over an Edge					
		Distance Along Edge (B), ft					
Setback Distance (C)		0	1	2	3	4	5
	1	12.0	12.5	13.5	14.5	15.5	
	2	12.0	12.5	13.0	13.5		
	3	12.0	12.5	13.0	13.5		
	4+	12.0	12.5				

WARNING

Do not work on the far side of an opening, opposite the SRL-LE anchorage point. Failure to heed this warning may result in serious injury or death.

4) SWING PENDULUM FALLS:

Swing falls occur when the anchorage point is not directly above the point where a fall occurs (see Figure 4). The force of striking an object in a swing fall may cause serious injury. In a swing fall, the total vertical fall distance will be greater than if the user had fallen directly below the anchorage point, thus increasing fall clearance required to safely arrest the user. Use Figures 2 and 3A through 3B to determine the fall clearance for your application. Minimize swing falls by working as directly below the anchorage point as possible. Never permit a swing fall if injury could occur.

Instructions for Use

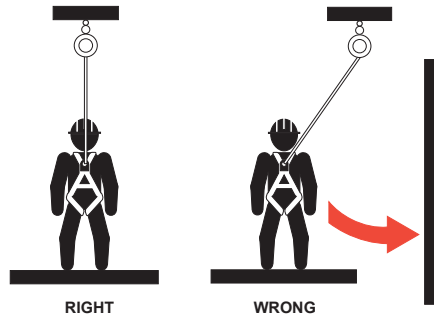

FIGURE 4

5) CHEMICAL HAZARDS:

Acidic, alkaline, or other environments with harsh substances may damage the webbing (if equipped) and hardware elements of this SRL. Polyester webbing is more resistant to attack by acids, but is subject to degradation by alkaline or neutral pH environments. If working in a chemically aggressive environment, an SRL that uses a cable Lanyard is generally recommended. When working in the presence of chemicals, more frequent inspection of the SRL is required.

6) HEAT:

Do not use SRL's that utilize a web Lanyard in environments with temperatures greater than 185°F (85°C). Protect the lanyard when used near welding, metal cutting, or other heat producing activities. Sparks may damage the lanyard cable and reduce its strength.

***IMPORTANT:** When working with tools, materials, or in high temperature environments, ensure that associated fall protection equipment can withstand high temperatures, or provide protection for those items.*

7) CORROSION:

Do not expose the device to corrosive environments for prolonged periods. Organic substances and salt water are particularly corrosive to metal parts. When working in a corrosive environment more frequent inspection, cleaning, and drying of the SRL-LE is required. See Care and Inspection sections for cleaning and inspection details.

8) ELECTRICAL HAZARDS:

Use extreme caution when working near energized electrical sources. Metal hardware on the SRL, the Lanyard itself, and on other components connected to it will conduct electric current. Maintain a safe working distance [preferably at least 10' (3m)] from electrical hazards.

9) MOVING MACHINERY:

When working near moving machinery parts (e.g. conveyors, rotating shafts, presses, etc.), make sure that loose equipment is secured. Maintain

a safe working distance from machinery that could entangle clothing, the Lanyard, the harness, or other components connected to it.

10) SHARP EDGES AND ABRASIVE SURFACES:

Do not expose lanyards to sharp edges or abrasive surfaces that could cut, tear, abrade, or damage the wire rope. If working around sharp edges and abrasive surfaces is unavoidable use heavy padding or other protective barriers to prevent direct contact. Contact Reliance before using an in-line energy absorbing component or lanyard with an SRL.

11) WEAR AND DETERIORATION:

Any SRL-LE which shows signs of excessive wear, deterioration or aging, must be removed from use and marked “UNUSABLE” until destroyed. **See detailed inspection procedures.**

NOTE

On Leading Edge SRL: Although this model provides additional protection from falls occurring over edges, protection against cutting must be provided when working near extremely sharp edges such as sheared, cold rolled, or flame cut steel, or rough cast edge concrete. Edge protection is not required over edges such as hot rolled steel, steel decking, chamfered concrete, or wood.

12) IMPACT FORCES:

Any SRL-LE that has been subjected to the forces of arresting a fall must be immediately removed from service and marked as “UNUSABLE” until recertified or replaced. RELIANCE SRL-LE’s have impact load indicators built into either the hooks or the anchorage component on top of the SRL-LE that facilitate inspection for fall loading.

13) WATER SUBMERSION:

If the SRL-LE is submersed in water for more than 4 hours, the unit must be removed from use and marked ‘UNUSABLE’ until destroyed. See detailed inspection procedures. If the unit has been submersed for less than 4 hours it must be completely dried before use. To dry, pull entire length of cable out of unit and hang from load-indicating swivel for 72 hours in a low-humidity environment.

SYSTEMS REQUIREMENTS

A. COMPATIBILITY OF SYSTEM PARTS

1) COMPATIBILITY OF COMPONENTS AND SUBSYSTEMS:

RELIANCE SRL-LE’s are designed to be used with RELIANCE approved components and connecting subsystems. Use of the SRL-LE with products made by others should be evaluated by a competent person to ensure compatibility of components and hardware. Connecting subsystems must be suitable for use in the application (e.g. fall arrest or restraint). RELIANCE manufactures a line of connecting subsystems for most applications. Contact

Instructions for Use

RELIANCE for further information. Refer to the manufacturer's instructions supplied with the component or connecting subsystem to determine suitability. Contact RELIANCE with any questions regarding compatibility of equipment used with the SRL.

2) COMPATIBILITY OF CONNECTORS

Connectors, such as D-rings, snap hooks, and carabiners, must be rated at 5,000 lb. (22 kN) minimum breaking strength and comply with ANSI Z359.12. RELIANCE connectors meet these requirements. Connecting hardware must be compatible in size, shape, and strength. Non-compatible connectors may accidentally disengage ("rollout") or false engage. Always verify that the connecting snap hook or carabiner and the D-ring on the harness or anchorage connector is compatible. Some harness models have web loop connection points. Do not use snap hooks to connect to web loops unless the snap hook complies with ANSI Z359.12. A self-locking carabiner may also be used to connect to a web loop. Ensure the carabiner cannot cross-gate load (load against the gate rather than along the backbone of the carabiner). Connecting subsystems (Self Retracting Lanyard, lanyard, rope grab and Lanyard, cable grab, etc.) must be suitable for your application.

EXAMPLES OF INAPPROPRIATE CONNECTIONS :

- A. To a D-ring to which another connector is attached
- B. In a manner that would result in a load on the gate.
- C. In a false engagement, where features that protrude from the snap hook or carabiner catch on the anchor and seem to be fully engaged to the anchor point. (Reliance has designed the width of the head and gates of Reliance snap hooks to prevent this issue in most D-rings.)
- D. To each other.
- E. Directly to webbing or rope lanyard or tie-back.
- F. To any object shaped such that the snap hook or carabiner will not close and lock, or that could cause roll-out should a fall occur.

3) ANCHORAGES AND ANCHORAGE CONNECTORS

Anchorage for personal fall arrest systems must have a strength capable of supporting a static load, applied in directions permitted by the system, of at least: (a) 3,600 lb. (16 kN) when certification exists, or (b) 5,000 lb. (22.2 kN) in the absence of certification. When more than one personal fall arrest system is attached to an anchorage, the anchorage strengths set forth in (a) and (b) must be multiplied by the number of systems attached to the anchorage. This requirement is consistent with OSHA requirements under 29 CFR 1910 & 1926.

Anchorage connectors must be selected carefully. Eyebolts should not be used if they will be loaded at an angle to their axis, unless the loads fall within design parameters for such use. Weld-on lugs should not be less than 1/2 in (12.7mm) in width and should not be made of steel with less than 50,000-PSI

yield strength. The proper stress areas and weld areas must be calculated to assure proper safety. If in question, consult Reliance Industries Engineering for proper design requirements.

INSTALLATION PROCEDURE

A. CONNECTING THE SRL-LE TO AN ANCHOR POINT

NOTE: Approved fall protection must be worn during Skyloc[™] Self-Retracting Lanyard installation at all times. Do not use the SRL as a method of personal fall protection until the system has been completely installed, inspected, and approved for use by a Qualified Person.

1. Installation of the Roto-Loc[™] Leading Edge Self-Retracting Lanyard begins with the identification of a suitable anchor point. The anchor point must be capable of supporting a 3,600 lb (16kN) load where certification of load carrying ability exists, or 5,000 lb (22.2kN) where certification does not exist. NOTE: These strengths must be multiplied by the number of persons that will be connecting to the anchorage point at any one time.
2. Pass a large carabiner or bow shackle (or other Reliance approved connecting means) through the swivel eye or handle at the top of the Roto-Loc[™]. This carabiner or bow shackle must be rated with a minimum breaking strength of at least 5,000 lb (22.2kN) and must be used for connecting to only 1 SRL at a time.
3. Secure the bow shackle or carabiner to the anchor point. If using a bow shackle, verify that it is a safety shackle and that the nut of the shackle has been fully captured using a clevis pin or lock ring to prevent accidentally disengagement. When using a carabiner make sure that the gate has fully closed and rotated into a locked position.

B. HARNESS MOUNTING THE SRL-LE WITH 4007-65

44XXXXX Series ROTO-LOC[™] SRL-LE'S can be connected directly to the harness webbing at the back D-Ring location utilizing the 4007-65 Connector (Figure 5).

1. Remove the clevis connector from the top of the SRD. Pass the clevis(s) through the 4007-65 anchor loop and reinstall anchor bolt to the clevis and secure anchor bolt with nut and supplied safety locking pin. (Up to 2 units may be connected to anchor loop of the 4007-65 adaptor bracket) (Fig 6)
2. Pull both webbing shoulder straps in the back D-Ring into a loop away from the black back plaque. Pull enough slack to create a loop large enough to allow the insertion of the bail connector through the webbing. (Fig 7)

Instructions for Use

3. Open the bail connector by turning the knurled knob 90 degrees and pulling spring loaded pin back while aligning the slots in the bail connector with the locking pin ends. Turn the spring loaded pin into the open lock detent to hold the spring loaded pin open. (Fig 8)
4. Pass the bail connector behind the webbing loop. Both shoulder strap webs must be captured by the bail connector. (Fig 9)
5. Twist the knurled knob to release the spring loaded pin from the lock detents, as the pin releases align the slots in the bail connector to the locking pin ends. Ensure the pin is fully inserted into the bail connector hole and locks 90 degrees into the center barrel. (Fig 10)
6. When properly engaged, the cross-pin on the end of the locking pin will be rotated to the key-way on the top bail approximately 90 degrees. (Fig 11)

WARNING

The bail connector must be locked inside the cross-pin of the locking pin as shown in Figure 11. If the connector pin is not properly locked as shown it may result in serious injury or death.

Removal is the opposite of installation. Contact Reliance to help identify specific installation methods for your situation.

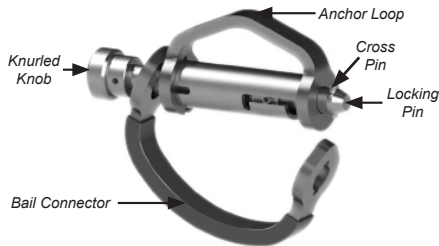

Figure 5

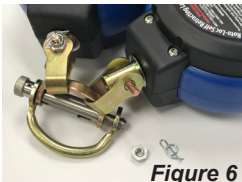

Figure 6



Figure 7

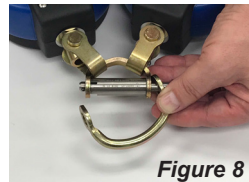

Figure 8



Figure 9



Figure 10

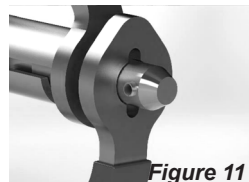

Figure 11



C. PREPARATION FOR USE

1. Once the Roto-Loc™ has been secured into position, extract a few feet of cable slowly to verify that there is tension on the line and the retraction spring is functioning correctly.
2. Give the cable a quick, sharp tug causing the unit to lock-up proving that the braking mechanism is operating correctly. Slowly allow the cable to be retracted back into the unit under the power of the retraction spring.

D. INSPECT PRIOR TO USE:

Before the use of this SRL-LE, inspect the SRL-LE and all components of the PFAS:

- 1) Inspect the SRL to verify that it is in serviceable condition. Examine every inch of the lanyard or cable for severe wear, cuts, burns, frayed edges, abrasion, or other damage. Examine stitching for any pulled, loose, or torn stitches. See Inspection section for details.

WARNING

Do not use if inspection reveals an unsafe condition. Always err on the side of safety.

E. PLAN SCOPE OF WORK TO BE PERFORMED (JOB SAFETY TASK ANALYSIS)

Plan procedures to safely perform tasks when using any components of a PFAS. Some considerations are listed below (see APPLICATIONS, item B. USE LIMITATIONS section for additional details)

WARNING

Use of this device while attached to a "foot-level" anchorage or while exposed to an unprotected structural edge should be a LAST RESORT. Every effort should be made to attach to a properly rated overhead anchorage in an effort to reduce the overall fall distance. DO NOT allow the retractable line to come into contact with a sharp, jagged, serrated or abrasive edge. A "foot-level" or "leading-edge" fall is likely to result in the injury of the user – the first hazard in the fall path is and always will be the structural edge, itself! Elevate your anchorage to the extent possible for the best outcome.

- 1) Anchorage Selection. In addition to strength considerations, the anchorage should be rigged to prevent a fall onto the structure when considering 2) and 4) below.
- 2) Swing pendulum fall
- 3) Rough surfaces or unprotected sharp edges that could cut or abrade

Instructions for Use

the equipment if unprotected.

4) Workplace geometry

- a) Free fall distance - Personal fall arrest systems used with this equipment should be mounted overhead in such a way as to eliminate the possibility of a free fall.
- b) Deceleration distance - See Clearance Charts for fall clearances
- c) Total fall distance - See Clearance Charts for fall clearances
- d) A careful examination must be made of the workplace by a Competent Person before the selection or installation of Roto-Loc™ anchorage points. Consideration must be given both to the movement of materials (Will cranes be used to “fly” equipment or parts in?) and workers around the workplace to ensure that potentially hazardous situations are avoided.
- e) Areas where overhead cranes or gantries are used must be examined to verify that neither the moving loads or lifting wires can interfere or snag the extended wire rope line of a ROTO-LOC™ SRL-LE causing a worker to be dislodged.
- f) Overhead lighting and electrical cables must also be identified to insure that installation of the SRL-LE is sufficiently far enough away so that the cable can never contact the wire creating an electrocution hazard.
- g) Consideration of obstacles present in the work area must include ALL locations that COULD be reached if the entire length of wire rope / web were extracted from the SRL-LE. Obstacles that pose no threat when a worker is on a platform, for example, may be exposed to a dangerous situation should he climb downwards or moves laterally towards another work surface.
- h) Although this model provides additional protection from falls occurring over edges, protection against cutting must be provided when working near extremely sharp edges such as sheared, cold rolled, flame cut steel, or rough cast edge concrete. Edge protection is not required over edges such as hot rolled steel, steel decking, chamfered concrete, or wood.
- i) Avoid installations where debris, contaminants, & other objects falling from above could damage the Roto-Loc™ and/or its cable line.
- j) Extreme caution must also be exercised when considering the use of the Roto-Loc™ SRL-LE as a means of fall protection in areas where a user is working on a sloped surface such as a pitched roof or tank bottom, or on piles of loose material (such as grain or sand) that may shift or slide. If the user falls or begins to slide on such a surface, the ROTO-LOC™ SRL-LE may not be extracted

fast enough for the device to lock-up (typically, the line must be extracted around 5-6ft/sec. for the unit to lock-up,) and arrest the sliding fall. The user might continue to slide over a roof edge, or into some other hazardous zone causing injury or death. The use of a travel restriction system or a work-positioning system may be more appropriate for such locations and should be considered first. Contact Reliance Engineering for help in selecting equipment for these applications.

- 5) Rescue and Evacuation - The user and employer must have a rescue plan in place, training in its use, and the means to implement it at hand. The employer must have the ability to perform a rescue quickly and safely. Do not plan to rely on others for rescue because prolonged suspension can cause bodily injury or death.

CARE OF THE ROTO-LOC[™] SRL-LE

- A. Clean exterior by wiping away excess dirt, grease, or other materials that might interfere with operation of the unit. Dry hardware with a clean, dry cloth, and hang to air dry. Do not attempt to disassemble the unit. A buildup of dirt, solvents, paint, etc. on the Lanyard may prevent the SRL-LE from working properly, and should be removed from service. More information on cleaning is available from RELIANCE. If you have questions concerning the condition of your SRL-LE, or have any doubt about putting it into service contact RELIANCE.
- B. Store SRL's in a cool, dry, clean environment. Avoid areas where heat, oil, chemicals or their vapors may exist. Thoroughly inspect after extended storage. Good safety practice requires separate storage of unusable product from usable product.

INSPECTIONS

A. INSPECTION FREQUENCY

- 1) The SRL-LE must be fully inspected by the user prior to each use.
- 2) A competent person other than the user must inspect the SRL in accordance with ANSI Z359.14-2014 as specified in the following inspection schedule.

Instructions for Use

ANSI Z359.14 Inspection Schedule			
Type of Use	Application Examples	Conditions of Use	Inspection Frequency
Frequent to Light	Rescue and Confined Space, Factory Maintenance	Good Storage Conditions, Indoor or Infrequent Outdoor Use, Room Temperature, Clean Environments	Annually
Moderate to Heavy	Transportation, Residential Construction, Utilities, Warehouse	Fair Storage Conditions, Indoor and Extended Outdoor Use, All Temperatures, Clean or Dusty Environments	Semi-Annually to Annually
Severe to Continuous	Commercial Construction, Oil & Gas, Mining	Harsh Storage Conditions, Prolonged or Continuous Outdoor Use, All Temperatures, Dirty Environments	Quarterly to Semi-Annually

Record the results of each formal inspection in the inspection and maintenance log as described.

B. INSPECTION PROCEDURE

- 1) Prior to each use, the worker must inspect the Roto-Loc™ Leading Edge Self-Retracting Lanyard for any physical damage, wear, corrosion, or malfunctioning parts. Verify that the load indicator is not visible by looking to see if the red button at the top of the swivel

Figure 12

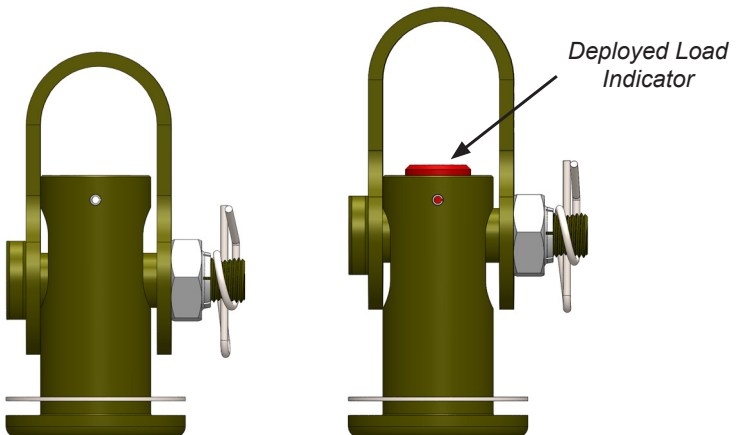

post on the anchor shackle is exposed (Figure 12). Once the load indicator has been deployed, the SRL-LE must be removed from service as the SRL-LE is not repairable.

- 2) The worker should also verify that conditions around the SRL-LE location have not changed that may affect its' ability to arrest a fall, such as obstacles or equipment directly below the anchorage point which might create a swing fall.
- 3) Before every use, the worker should extract all of the cable line and examine it for defects that would affect its overall strength. These defects would include but are not limited to weld strikes or burns, kinks, bends, "bird-caging", bulge spots, outer diameter thinning, broken or snagged wire strands, etc. If the cable line is showing evidence of any of these defects, the unit should be removed from service immediately as this unit is not serviceable. The ferrules of the cable, by the snaphook should also be examined for cracks, or deformation.
- 4) After the wire rope has been allowed to retract into the unit, the snaphook should be pulled sharply to verify proper lockup of the unit. If unit fails to lockup when pulled quickly, or if the cable fails to retract properly after lockup, the unit must be removed from service until repaired.
- 5) Carefully inspect the plastic housing for cracks or fractures. Evidence of cracks or fractures requires factory-authorized inspection. Scuffing and minor indentations that do not inhibit the retraction of the unit are cosmetic issues.

TRAINING

It is the responsibility of the employer to train all workers prior to using this system (per OSHA 1926.503 (a)(1)). The employer shall provide a training program for each employee who might be exposed to fall hazards. The program shall enable each employee to recognize the hazards of falling and shall train each employee in the procedures to be followed in order to minimize these hazards. The employer shall assure that, as necessary, each employee has been trained by a competent person qualified in the following areas:

- 1) OSHA regulations governing the use of horizontal Lanyards.
- 2) Ability to recognize potential fall and workplace hazards.
- 3) Method of inspection of safety equipment.
- 4) Rescue procedures.

Instructions for Use

5) Installation and removal techniques.

RESCUE PLANNING

Prior to system use, a rescue plan must be prepared, the workers must be trained in its use, and the rescue equipment must be on hand to implement it in case of a fall. Typical rescue plans include (but are not limited to) the following items:

- 1) List of equipment that must be readily accessible in the event of an emergency and the names of those workers certified to use or operate that equipment.
- 2) Emergency contact phone numbers (ambulance, hospital, fire department...) and a means to contact them (cell phone, emergency radio).
- 3) List of employees on the site, and the specific tasks they will perform to effect the rescue.
- 4) The equipment that will be used to aid in the rescue of any worker should be attached to structural anchorages independent of those used for the personal fall arrest system. During installation of anchorages, tie-off and equipment attachment hard points should be attached, and also clearly marked in such a manner as to provide a means to rescue a worker in any position along the worksite.

SERVICING

ROTO-LOC™ SRL-LE's are not repairable. If the SRL-LE has been subjected to fall arrest forces or inspection reveals an unsafe or defective condition, remove the SRL-LE from service, mark "UNUSABLE", and dispose of the unit.

GUARDING AGAINST APPLICATION FAILURE

To avoid property damage, injury or death, the User must take reasonable steps to prevent "Application Failure". An application failure may be any unacceptable use, misuse, or application error on the part of the User or System Designer. Because each end user might use this product in a manner different from Reliance Industries testing platform, and because the User might use this product in combination with other manufacturer's products in a manner not evaluated, contemplated, or tested by Reliance, the User or System Designer is ultimately responsible for verifying or validating the suitability and compatibility of this product for use in his



application or system. Whenever questions regarding proper use or compatibility arise, please contact Reliance Engineering at (303) 424-8650.

WARNINGS AND LIMITATIONS

- 1) Proper care should always be taken to visually scan the work area prior to use. Remove any obstruction, debris, and other materials from, and beneath the work area that could cause injuries or interfere with the operation of this system. Be cautious of swing fall hazards if working anywhere but directly below the anchorage point of the SRL. Be aware of the movements of others using SRL's or shock-absorbing lanyards in close proximity, knowing that if the lines become crossed or tangled and a fall occurs, the sudden motion could pull others off balance and make rescue more difficult.
- 2) Do not release the cable line when extended and allow it to retract back into the unit uncontrollably. Releasing the cable line and allowing it to reel itself in uncontrollably could cause damage to the Roto-Loc™. The cable line should be allowed to retract slowly into the unit under its' own power.
- 3) In the course of use, do not allow the cable, rope, or web line to wrap around arms or legs, or become entangled in clothing or other items. In the event of a fall, they could cause injury, or prevent the Roto-Loc™ SRL-LE from functioning properly. Any Roto-Loc™ Leading Edge Self Retracting Lanyard that has the load indicator of the anchor swivel showing (deployed) has seen a fall-arrest load and must be removed from service, mark "UNUSABLE", and dispose of the unit. Roto-Loc™ SRL-LE's are not repairable.
- 4) Users should be familiar with pertinent regulations governing the use of this personal fall arrest system and its components. Only trained and competent personnel should install and supervise the use of this system.
- 5) Use only Reliance supplied or qualified compatible components.
- 6) Do not tie knots in the cable line of the unit. Tying knots in cable line reduces the overall strength of the wire rope. Do not cross lines with another worker. Should the lines become entangled, a fall by one worker could dislodge others.

Instructions for Use

LABELING

The illustrations here are representations of the actual labels that appear on Reliance Roto-Loc™ Leading Edge Self Retracting Lanyards.

All the information on the SRL-LE Specifications Label is important for the safe use of this product, so the user should ensure that the label has not been removed and that the descriptions it contains match the task and environment in which the product is intended to be used. An inspection log is available on page 22 of this manual. The unit should be inspected by a Competent Person at periodic intervals and at least monthly. As per these instructions, the unit should be tested for locking before each use.

PRODUCT LABELS

Roto-Loc Self Retracting Lanyard - Leading Edge

READ & HEED ALL LABELS, WARNINGS, & INSTRUCTIONS PRIOR TO USE.

MEETS: ANSI Z359.14, CLASS B - LINE MATERIAL: Galvanized Steel
 WORKING LENGTH: 6 ft - MAX. FREE FALL: 6 ft
 MAX. ARREST FORCE ≤ 1800 lbs - AVG. ARREST FORCE ≤ 1350 lbs
 CAPACITY: 90-310 lbs
 MINIMUM INSTALLATION SETBACK DISTANCE: 1 ft
 This product meets or exceeds the requirements of ANSI Z359.14 and applicable OSHA regulations.

WARNING: Before using, read, understand and adhere to manufacturer's instructions included with equipment at time of shipment. Before each use, user must inspect & test this product in accordance with the manufacturer's instructions, & must test locking function and retraction.

DO NOT use this product if it has been used to arrest a fall or if visual indicator is activated.
DO NOT climb above anchorage or rig so as to exceed Maximum Free-Fall cited at the top of this label.
DO NOT install or use near electrical hazards or energized equipment.

ANCHORAGE: The anchorage to which this device is attached must be capable of supporting 5,000 lbs or must be certified by a qualified engineer as having a minimum safety factor of 2:1.

CAUTION: This device is approved for use with Reliance Horizontal Lifeline Systems
CAUTION: This device may be used on the horizontal plane, and leading edge applications.

IMPORTANT: This device includes a visual indicator built into the top swivel. The exposed red button protruding from top of anchor swivel indicates impact loading. If exposed, unit must be removed from service immediately.

INSTALLATION & USE: Attach this device to a compatible connector on the anchorage meeting the above stated requirements. Ensure that the connector cannot be loaded in a manner that may lead to accidental disengagement.

WARNING: This SRL-LE is for personal fall arrest ONLY. Users of this device must be trained in its use prior to beginning work. If instructions are missing, please contact Reliance for a replacement set.

Reliance Industries Deer Park, TX 77536
 281.930.8000 - www.reliance.com

Label PN 440006-033 Rev B

DOM	S/N	P/N
PINK AREA IS A CLEAR WINDOW		

Leading Edge Clearance Chart

OFF AXIS 1' | 2' | 3' | 4' | 5' | 6'

15.5' | 13.5' | 12' | 13.5' | 15.5'

4485006-1, 4486006-1, 4495006-1, 4495006-Z, 4496006-1, 4496006-Z,
 4487006-1, 4480006-1, 4497006-1, 4490006-1

Instructions for Use

These Instructions Apply to the Following Part Numbers :

4485006-1
4486006-1
4487006-1
4480006-1
4495006-1
4495006-Z
4496006-1
4496006-Z
4497006-1
4490006-1

Warranty

Products manufactured by Reliance Industries LLC are warranted against factory defects in workmanship and materials for a period of two years from date of purchase by the owner (end user) or for a period of one year from date first used, provided that this period shall not exceed two years from date of shipment to distributor. Upon notice of product defect or fault, Reliance Industries LLC will promptly repair or replace all defective items. Reliance Industries LLC reserves the right to elect to have any defective item returned to its manufacturing plant, authorized service center or distributor for inspection before making a repair or replacement. This warranty does not cover equipment damages or defects resulting from abuse, damage in transit, or other damage beyond the control of Reliance Industries. This warranty applies only to the original purchaser and is the only one applicable to our products and services, and is in lieu of all other warranties, expressed or implied. When products offered by Reliance Industries LLC are manufactured by a third party. Original equipment manufacturer (OEM) warranty shall apply and may be outside the control of Reliance Industries LLC.



Reliance Industries
P.O. Box 2046
Deer Park, TX 77536
Phone : 281-930-8000
Toll Free : 888-362-2826
Fax : 281-930-8666
www.relsafe.com