



# Operating instructions

for

## Skyline™ Beam Clamp

**Model # 3093**

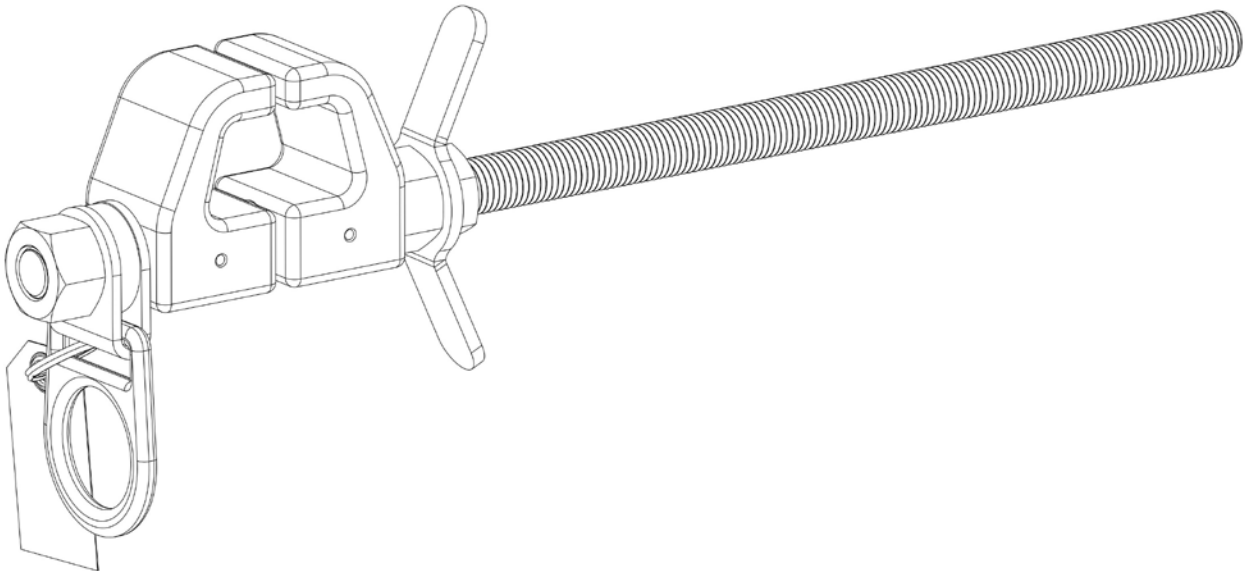

Reliance Industries, LLC  
Deer Park, TX 77536  
Ph. (888) 362-2826  
Ph. (281) 930-8000  
Fax (281) 930-8666

# User Instructions

## 3093 Skyline™ Beam Clamp



Reliance Industries, LLC

### General Instructions

It is the responsibility of the employer, as part of a total fall arrest rescue and evacuation program, to retain the manufacturer's instructions and make them readily available to all users. The employer must provide adequate training in the proper use and care of this product prior to use.

#### Manufacturer's name and address

Reliance Industries, LLC  
Deer Park, TX 77536  
Ph. (888) 3622826  
Ph. (281) 9308000  
Fax (281) 9308666

#### Part Number and Model Designation

Model type: Skyline™ Beam Clamp  
Part number: Model # 3093 for 4.00" to 16.625" range  
Proof Load: 14,000 lbs in-line pull on D-ring  
Rated capacity: 7,000-lb. (3175 kg) horizontal lifeline load  
400-lb. (181 kg) personal fall arrest anchorage  
Range of beam sizes: I-beam flange width range 4.00-in. min. to 16-5/8-in. maximum with beam flange thickness from to .5-in. to 1.75-in.  
Material: 6061-T6 Aluminum  
High strength steel. Zinc plated with yellow chromate  
Caution: Always certify, using a qualified person, that the beam to which the Skyline™ Beam Clamp is being attached will carry the intended loads per OSHA and ANSI standards. For personal use with shock absorbing lanyard or a retractables designed for personal fall arrest with a 1800 lbs max. arrest force. The anchorage must be capable of sustaining a load of 5,000 lbs when used as PFAS. When attaching a lifeline to the d-ring, ensure that the lifeline is designed so that anticipated cable tensions do not exceed 7,000 lbs.  
  
When using as a HLL anchorage, always insure that the beam to which the Beam Clamp is attached will support the 7,000 lb. maximum anticipated load with a 2 to 1 safety factor (which is 14,000 lbs or greater).

# User Instructions

## 3093 Skyline™ Beam Clamp



Reliance Industries, LLC

### 3093 Skyline™ Beam Clamp Components

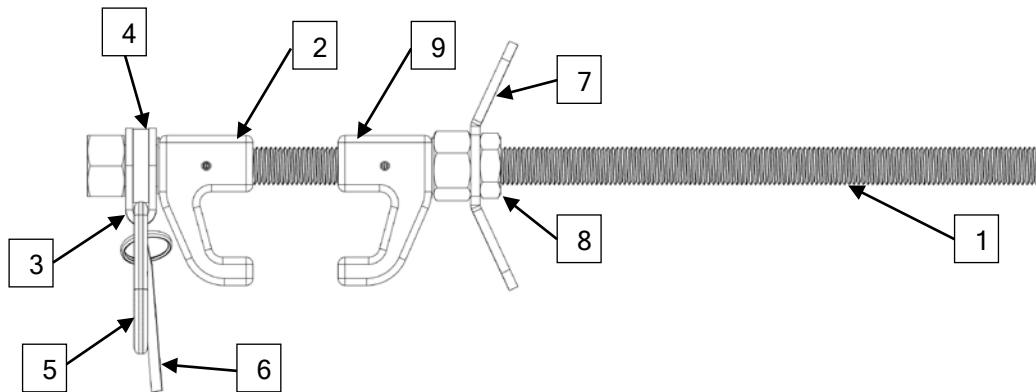

- |                     |                        |                       |
|---------------------|------------------------|-----------------------|
| 1. Threaded Rod     | 4. Yoke Spacer         | 7. Hand-Knob          |
| 2. Clamp Jaw, Fixed | 5. D-Ring              | 8. Jam Nut            |
| 3. D-ring Yoke      | 6. Anchor Clamp Labels | 9. Clamp Jaw, Movable |

### Intended use and purpose of the equipment

The Skyline™ Beam Clamp is an anchorage connector intended for use only for connection to I-beams with rigid flanges with thicknesses of 0.50-in. to 1.75-in. An anchorage is a secure means of attachment to which the personal fall arrest system is connected. Anchorage connectors are components with means specifically intended for coupling a personal fall arrest system to an overhead anchorage. The Skyline™ Beam Clamp provides a d-ring attachment for a single person fall arrest attachment point, or as a Skyline™ Horizontal Lifeline (HLL) attachment point, and a hand-knob for easy attachment. The handle must not be side-loaded, used as a fall arrest attachment point, or used as a footrest.

## User Instructions

### 3093 Skyline™ Beam Clamp



Reliance Industries, LLC

#### Proper method of use

The Skyline™ Beam Clamp is designed as a portable anchorage that can be temporarily installed to a structural I-beam to provide a rigid personal fall arrest (PFA) anchorage for fall arrest for one person only or as an anchorage for an HLL system. It can be attached to the following structures of an I-beam when properly torqued to 40-ft-lbs:

- Top or bottom flanges, of horizontal or vertical I-beams.

This system consists of a Beam Clamp with an integral d-ring for use as a PFA anchorage point and can be connected with locking snaphooks or carabiners or swaged cable ends. Or the d-ring can be used as an attachment point for a properly designed Skyline™ Horizontal Lifeline. **CAUTION: DO NOT** use the d-ring as both an attachment point for a personal fall arrest system and a horizontal lifeline system at the same time, it may be used for one or the other at any time but **NOT** both. Use only the swivel ring as a personal fall arrest attachment point. The anchor clamp has a gate opening to fit onto I-beam flanges in the range from

- 4.00 inch (10.16 cm) minimum to
- 16.625 inch (42.23 cm) maximum
- max. flange thickness of ½-in. (1.27 cm) to 1.75-in. (4.45 cm)

#### To attach the Beam Clamp:

Loosen the lock nut and hand-knob to desired width, slip over the I-beam flange as shown in Figure 1, align jaws parallel to flange edges and tighten the hand-knob as to 40-ft-lb. Tighten the lock nut to the to the hand-knob to lock the hand-knob in place. Check tightness again prior to each use.

**DO NOT** stand on either the nut, threaded rod or the handknob.

**DO NOT** use if the clamp does not grip the beam securely enough to prevent any side movement up or down the beam.

**DO NOT** use on open ended beams.

## User Instructions

### 3093 Skyline™ Beam Clamp



Reliance Industries, LLC

#### Caution !

- For HLL application, use d-ring anchorage only with the Skyline™ HLL system using 3/8-7 x 19 steel cable and the Skyline™ Shock Absorber pre-tensioned to 1000 lbf.
- When used as an end anchorage for horizontal lifelines, the lifeline may be attached to the clamp in the directions shown in **Figure 2**. Use only with HLL systems in which the anticipated maximum line tension does not exceed 7000 lbf.
- Do not replace factory supplied bolt with any substitute.
- The beam grip swivel ring can be loaded in any direction in which the eye swivels.
- When used as a personal fall arrest attachment anchorage, use only in the supplied configurations as shown in **Figure 1**.
- Do not install on open ended I-beam or structure.
- Do not use with non-locking snaphooks. Use only in conjunction with Personal Fall Arrest Systems, including shock absorbing lanyards or retractables and a full body harness.
- Do not install in corrosive environments that will cause degradation or corrosion of steel or zinc plated components.
- Do not use when the danger of lightning strike exists.
- Do not install or use near electrical hazards.
- Do not install this anchor clamp at elevations that will allow the worker to strike a lower level or objects that are below him in case of a fall.
- Do not tie off to the swivel ring when standing on a level above the location of the clamp. This will create a freefall greater than 6 ft. Instead, use an additional anchor clamp above the worker.

This product should be used only according with these instructions and in accordance with all state, federal and local safety regulations. The worker must read, heed and understand all warnings and instructions called out in the labels and operating instructions prior to use. Any hazards to safe and proper operation must be eliminated prior to use.

## **User Instructions**

### **3093 Skyline™ Beam Clamp**



**Reliance Industries, LLC**

When used as a personal fall arrest anchorage only, the anchorages and attachment components must be able to withstand a sustained force of 5000 Lbs. Anchorages selected for PFAS shall have a strength capable of sustaining static loads, applied in the directions permitted by the PFAS, of at least: a) 3,600 pounds (16 kN) when certification exists, or b) 5,000 pounds (22.2 kN) in the absence of certification, per OSHA regulations.

The manufacturer is not responsible for damages resulting from an improper application or use of this product. Proper application also means considering the operating instructions, workplace geometry, workplace hazards and the conditions of inspection and maintenance.

The user must have a rescue plan, be trained in the use of this plan and the means at hand to implement it when using this equipment.

Damaged products and products having already been used for arresting a fall must be removed from service.

Whenever the structure to which this anchor clamp is attached is altered the suitability of the anchor clamp as an anchorage must be recertified by a qualified person. Periodic inspections should be conducted by this qualified person at least once yearly.

Always use a qualified person or trained engineer to determine if the structure to which the anchor clamp is attached, is of sufficient strength to support the anticipated loads whether that is 5000 lbs through the swivel eye for a personal fall arrest anchorage or 14000 lbs for a horizontal lifeline anchorage.

Always use this product only with shock absorbing lanyards or SRLs attached only to the dorsal d-ring of the workers harness.

When using this anchor clamp for a personal fall arrest anchorage, always install the clamp at an elevation at least as high or higher than the worker's dorsal d-ring to limit freefall to 6 ft. or less, per OSHA requirements.

This product is qualified for use as a personal fall arrest anchorage only with shock absorbing lanyards or SRL's, and only when the freefall is limited to 6 ft. or less. Use only with locking snap hooks.

 **Warnings**

- **Do not alter or attempt to repair the equipment.**
- **Do not replace bolts with any substitute.**
- **Use equipment for intended purpose only.**
- **Do not use combinations of components or subsystems, or both, which may affect or interfere with the safe function of each other.**
- **Do not expose equipment to chemicals which may produce a harmful effect. Consult the manufacturer in cases of doubt.**
- **Do not use equipment around moving machinery and electrical hazards. Do not use equipment near sharp edges and abrasive surfaces. Avoid exposure to physical and chemical hazards which the product is not designed to withstand.**
- **Make only compatible connections. This product may only be used in connection with a safety harness as per ANSI Z359.11 and OSHA regulations. This product is designed for single person usage in conjunction with a full body harness and compatible anchorage devices. Only approved safety devices that comply with ANSI Z359 and OSHA regulations may be used with this product.**
- **Anchorage selected for personal fall arrest systems (PFAS) shall have a strength capable of sustaining static loads, applied in the directions permitted by the PFAS, of at least: (a) 3,600 pounds (16 kN) when certification exists, or (b) 5,000 pounds (22.2 kN) in the absence of certification, per OSHA regulations.**
- **Anchorage connectors shall be attached to no more than one personal fall arrest system unless certified for such purpose.**
- **Follow all limitations to the use of this anchor clamp as outlined in the section “Proper Method of Use.” Failure to do so may result in serious injury or death.**

**User Instructions**  
**3093 Skyline™ Beam Clamp**



**Reliance Industries, LLC**

**Skyline™ Beam Clamp Model # 3093**

**Permissible installation configurations when used as a personal fall arrest anchorage.**

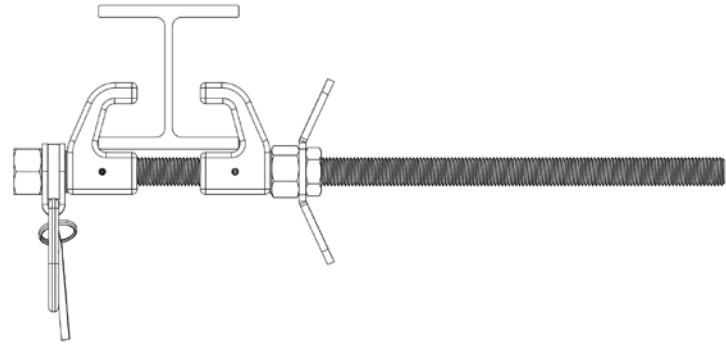
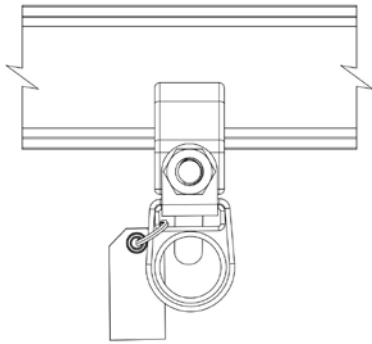

**Below Horizontal Beam Mounting**

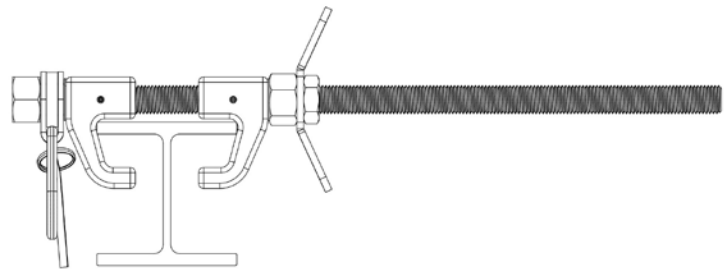
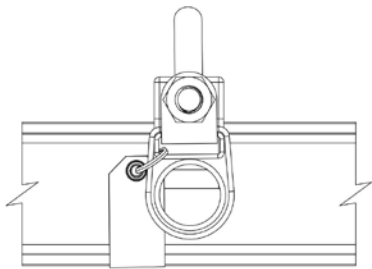

**Above Horizontal Beam Mounting**

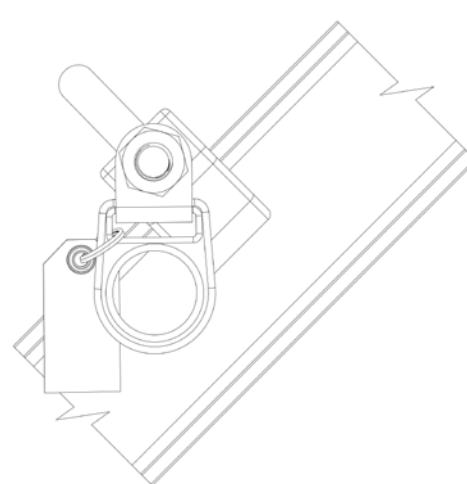
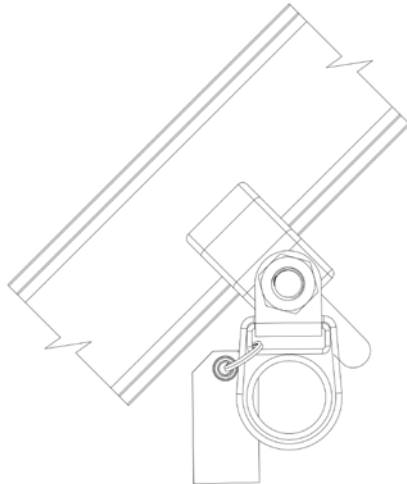

**Below Diagonal Beam Mounting**

**Above Diagonal Beam Mounting**

**Figure 1**



**User Instructions**  
**3093 Skyline™ Beam Clamp**



**Reliance Industries, LLC**

**Skyline™ Beam Clamp Model # 3093**

**Permissible methods of attachment when used as a horizontal lifeline anchorage.**

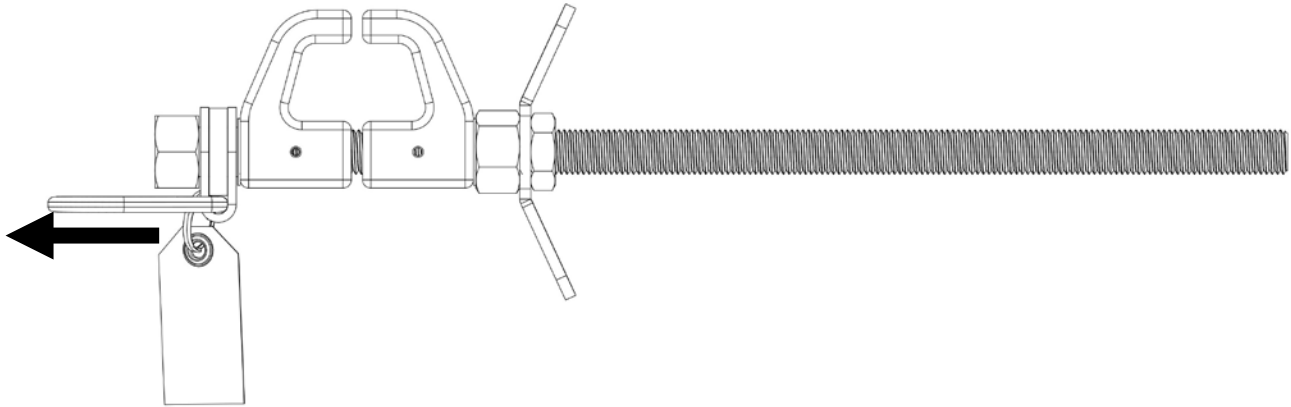

Acceptable HLL attachment and pull directions. DO NOT use for personal fall arrest anchorage when an HLL is attached.

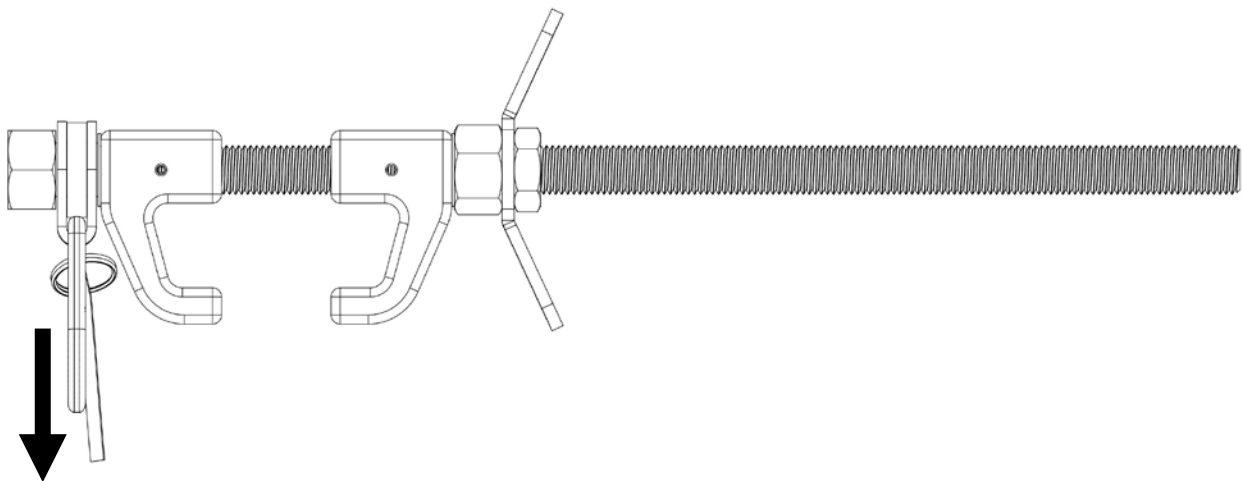

**Figure 2**

## Inspection, Maintenance and Storage

The user of this product is responsible for the execution of inspection, maintenance and possible repairs. The user shall inspect equipment before each use to ensure that the equipment is in serviceable condition and operating correctly.

A yearly inspection of this product should be performed by a qualified person capable of determining the suitability for use.

In addition to this, the product must be checked for possible damages after any fall arrest load has been applied and is to be examined by an expert who must then decide if the product is suitable for further use.

The user must remove equipment from field service that has been subjected to a fall arrest. An authorized inspection is then required to determine if the product is suitable for further use.

When any inspection reveals defects in, damage to, or inadequate maintenance of equipment, the equipment shall be tagged as “**UNUSABLE**” and be permanently removed from service or undergo adequate corrective maintenance by means of an authorized inspection before being returned to service.

Most common defects are for example:

- Loose locking nut
- Absence of any elements affecting the equipment form, fit or function
- Evidence of defects in or damage to hardware elements including cracks, sharp edges, deformation, corrosion, chemical attack, excessive heating, alteration and excessive wear
- Missing or unreadable labels and warnings
- Improper attachment to beam for intended use

Prior to installation equipment shall be stored in a cool, dry, and clean place away from direct sunlight in a manner as to preclude damage from environmental factors such as heat, light, excessive moisture, oil, chemicals and their vapors or other degrading elements.

## Cleaning

Product may be cleaned with soap and water or solvents that do not contain chlorine or chemicals corrosive to steel or zinc. Dry thoroughly after cleaning.

**User Instructions**  
**3093 Skyline™ Beam Clamp**



**Reliance Industries, LLC**

**Formal Inspection**

**Buyer/client:**

**Product description: Skyline™ Beam Clamp**

**Model No. 3093**

**Year of manufacture:**

**Date of purchase:**

**Date of first use:**

**Name of user:**

This formal inspection grid and log has to be filed at the buyers department of occupational health and safety and is to be sent along with the product for the annual formal inspection through a competent person. Only completely inspected products are subject of the product warranty and liability of the distributor and manufacturer.

**Inspected according to specifications outlined by manufacturer:**

By:	Date:	By:	Date:
Stamp	Signature	Stamp	Signature

By:	Date:	By:	Date:
Stamp	Signature	Stamp	Signature

By:	Date:	By:	Date:
Stamp	Signature	Stamp	Signature

The inspector confirms with his signature the compliance of his inspection with all specifications as outlined by the manufacturer and as required by standards and regulations pertaining to occupational health and safety and fall protection.

**User Instructions**  
**3093 Skyline™ Beam Clamp**



**Reliance Industries, LLC**

**Checklist**

**Skyline™ Beam Clamp Model No.: 3093**

	1. Year	2. Year	3. Year	4. Year	5. Year	6. Year
	Date	Date	Date	Date	Date	Date
By a qualified person:	Inspector	Inspector	Inspector	Inspector	Inspector	Inspector

**Skyline™ Beam Clamp:**

No missing parts						
No Corrosion						
No deformation						
Functioning condition						
No changes to attachment structure						

© Copyright by Reliance Industries, LLC - Excerpts and duplication of this formal inspection grid and log only with prior consent.